

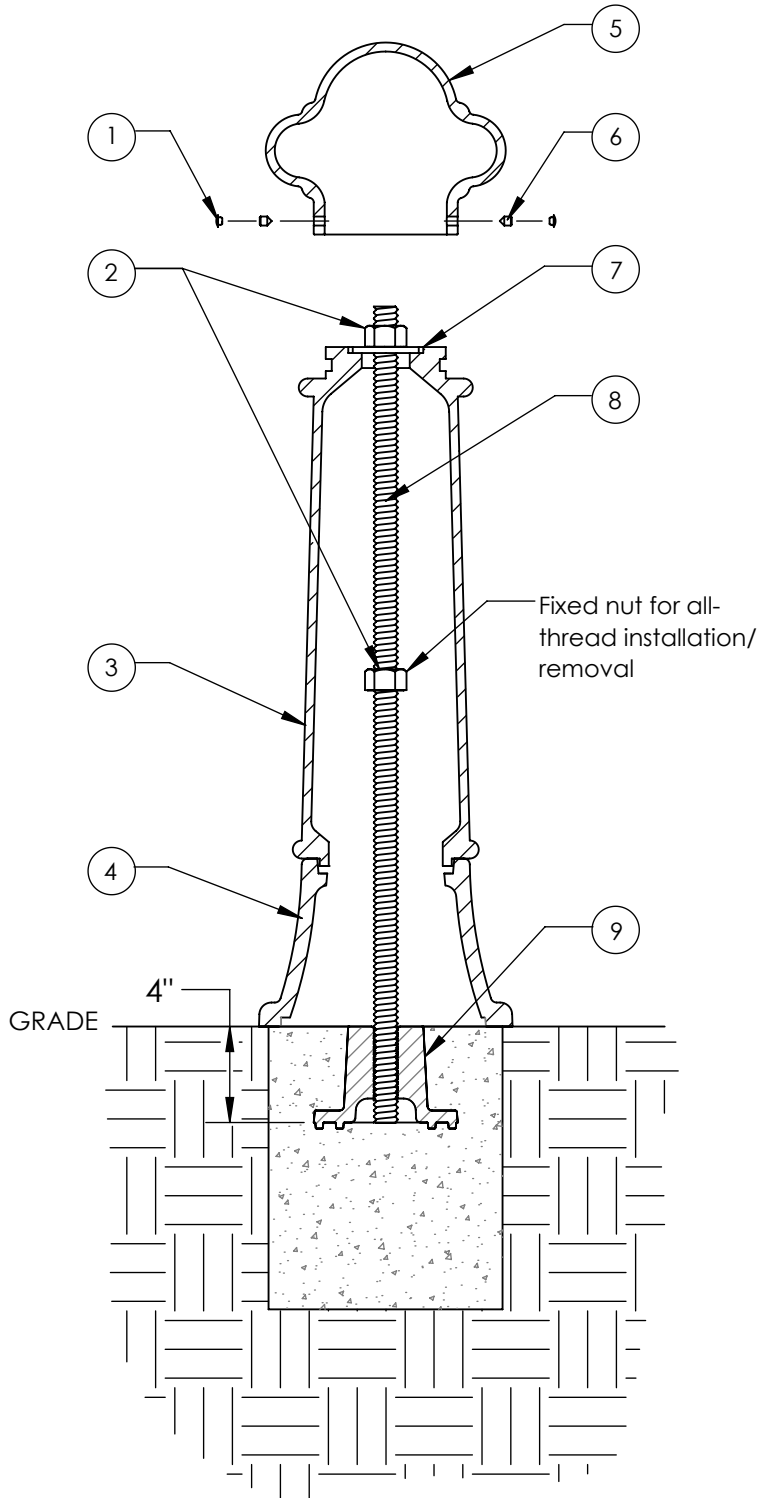

# Type I - Iron Base Mount

Series: Classic

Product Number: 150-QT



| ITEM | QTY | PART   | WEIGHT       |
|------|-----|--|--------------|
| 1    | 2   | Plastic screw caps .                         | .18 g. ea.   |
| 2    | 2   | 1" Stainless steel nut.                      | .34 lbs. ea. |
| 3    | 1   | Cast Iron plain bollard body.                | 51.6 lbs.    |
| 4    | 1   | Cast Iron taper bollard base.                | 31.7 lbs.    |
| 5    | 1   | Cast Iron queen bollard top.                 | 23.2 lbs.    |
| 6    | 2   | 3/8" stainless steel set screws.             | 3.7 g. ea.   |
| 7    | 1   | 1" stainless steel washer.                   | .36 lbs.     |
| 8    | 1   | 35"-long 1" dia. stainless steel all-thread. | 6.35 lbs.    |
| 9    | 1   | Ductile iron mounting base.                  | 9.6 lbs.     |

-Insert threaded rod into conc-embedded anchor casting, tighten 1" nut onto washer securing bollard in place, use set screws to secure Queen top.

-Footer detail is for reference only; proper footer construction depends on local soil conditions and engineering requirements.