

Type R1 - Twist & Lock

Series: 150 Century

Product Number: 150-GTF

ITEM	QTY	PART	WEIGHT
1	2	3/8" Plastic screw caps.	.18 g. ea.
2	2	1" Plastic bar hole caps.	5 g. ea.
3	1	150 Cast Iron flute body.	58 lbs.
4	1	150 Cast Iron taper base.	31.7 lbs.
5	1	6" Cast Iron Globe top.	20.6 lbs.
6	2	3/8" Stainless steel set screws.	2.7 g. ea.
7	1	30" Steel Install/Removal Bar.	3.8 lbs.
8	1	150 Steel locking pipe	15 lbs.
9	1	150 Cast Iron Twist&Lock Base.	46.4 lbs.
10	1	Removable steel plug.	9.25 lbs.

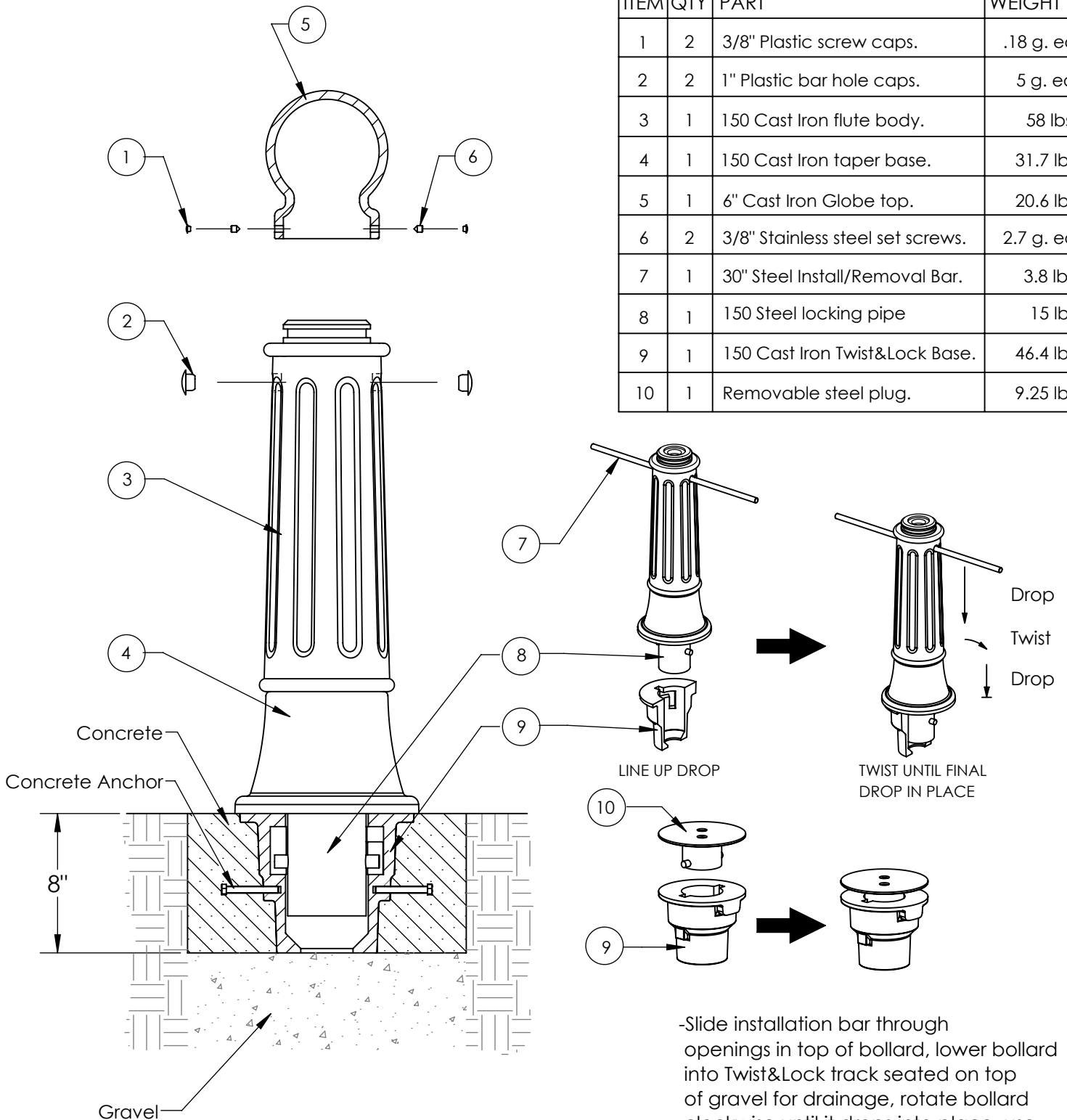

-Slide installation bar through openings in top of bollard, lower bollard into Twist&Lock track seated on top of gravel for drainage, rotate bollard clockwise until it drops into place, use set screws to secure Globe top.

-Footer detail is for reference only; proper footer construction depends on local soil conditions and engineering requirements.