

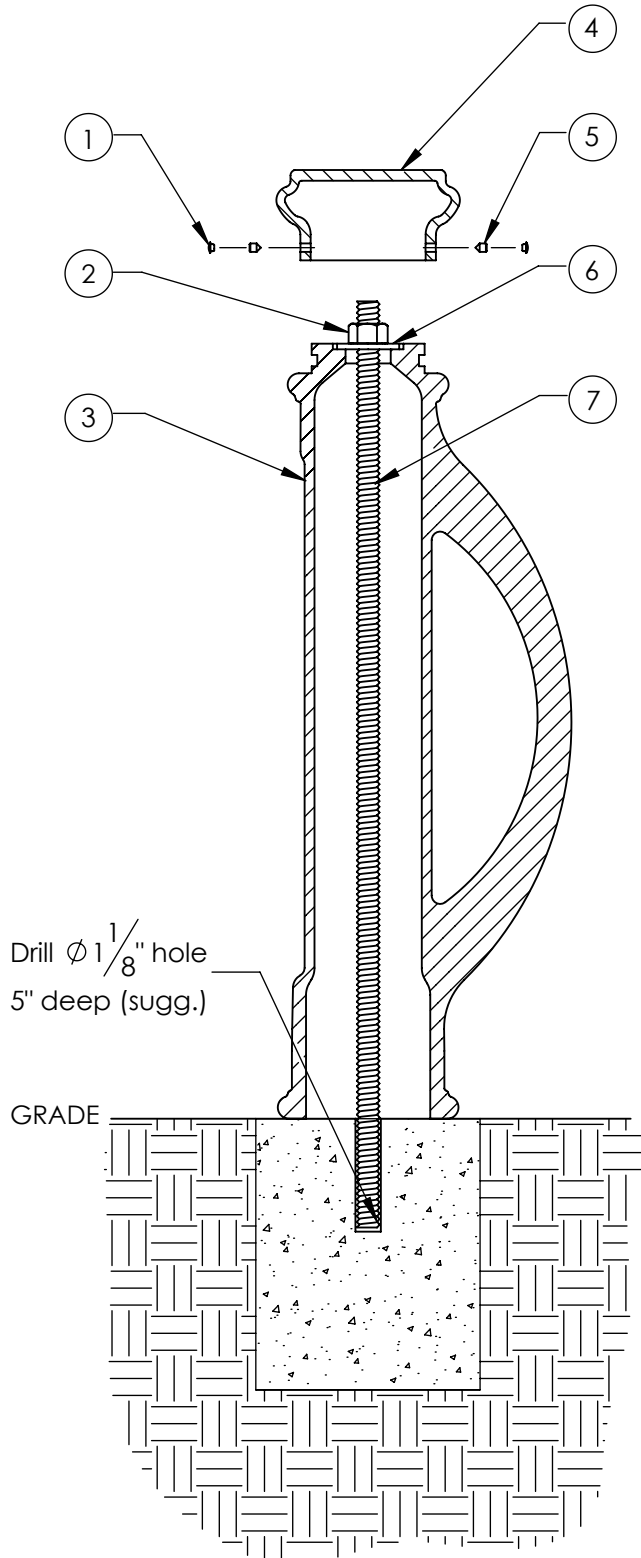

Type S - Surface Mount

Series: Velocity

Product Number: 160-GB1



ITEM	QTY	PART	WEIGHT
1	2	Plastic screw caps.	.18 g. ea.
2	1	1" Stainless steel nuts.	.34 lbs.
3	1	Cast Iron plain B1 bollard body.	118.2 lbs.
4	1	Cast Iron round bollard top.	13.6 lbs.
5	2	3/8" Stainless steel set screws.	3.7 g. ea.
6	1	1" Stainless steel washer.	.36 lbs.
7	1	41"-long 1" dia. stainless steel all-thread.	7.44 lbs.

-Anchor threaded rod into concrete with anchoring adhesive, tighten 1" nut onto washer securing bollard in place, use set screws to secure globe top.

-Footer detail is for reference only; proper footer construction depends on local soil conditions and engineering requirements.